

THIS DRAWING IS UNPUBLISHED. RELEASED FOR PUBLICATION ,19 .  
 © COPYRIGHT 19 BY AMP INCORPORATED, HARRISBURG, PA. ALL INTERNATIONAL RIGHTS RESERVED. AMP PRODUCTS MAY BE COVERED BY U.S. AND FOREIGN PATENTS AND/OR PATENTS PENDING.

LOC	DIST	P	F	ZONE	LTR	DESCRIPTION	DATE	APPROVED
AF	50				A	RELEASED PER F.A.S.R.	5/11/89	MSF

IDENTIFICATION NUMBER 15 FOR MAGNET WIRE RANGE.

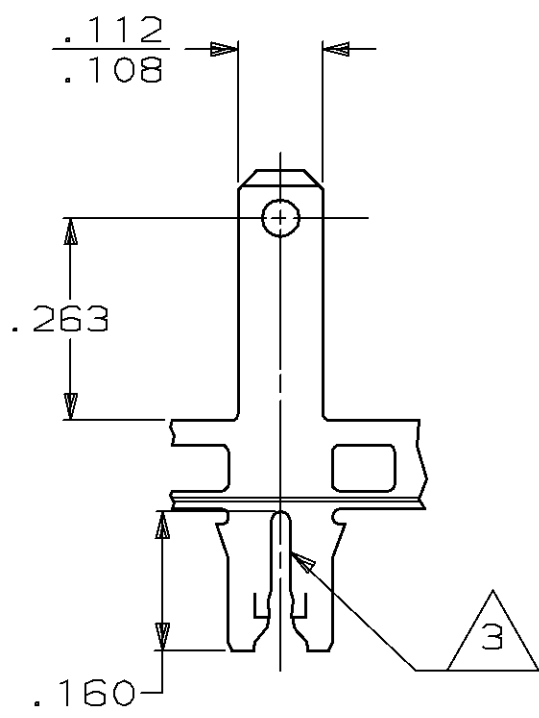
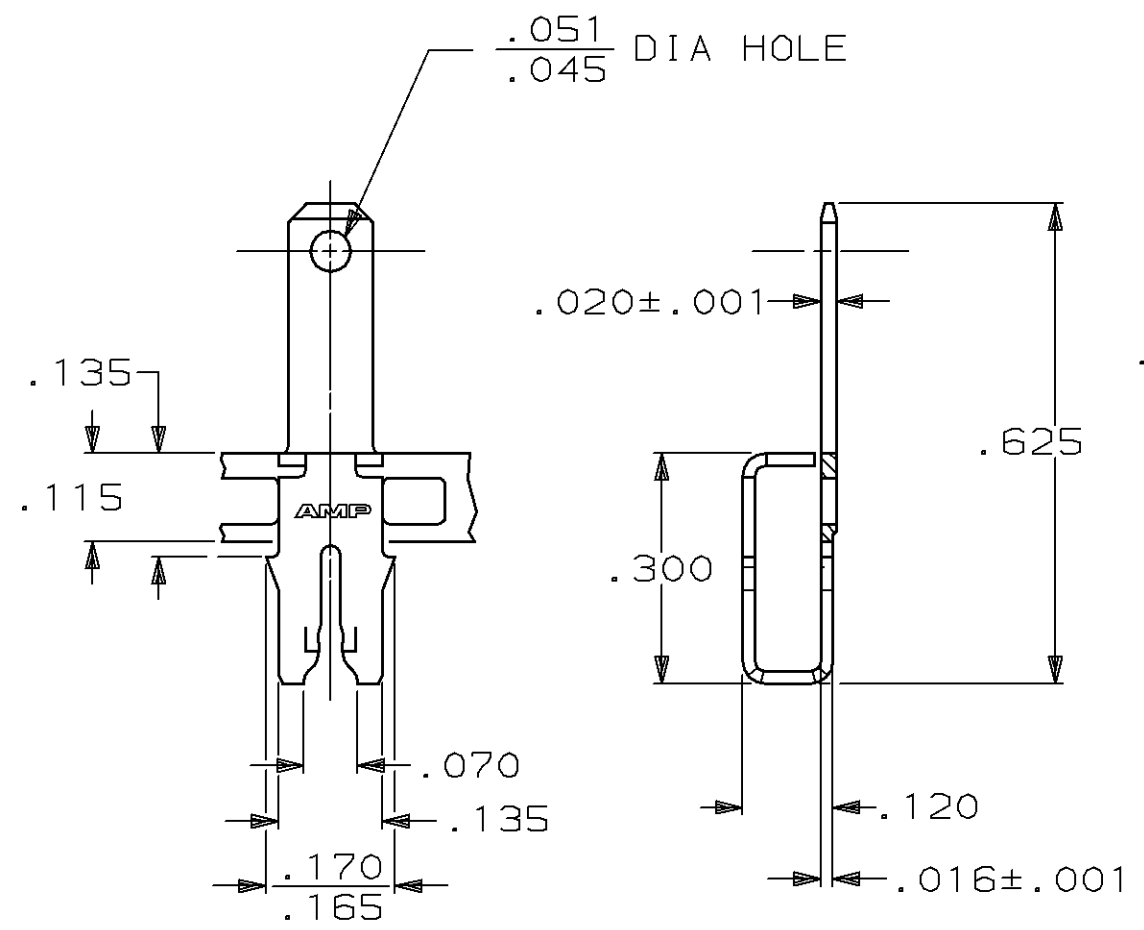
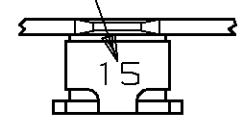

- 1 MAG-MATE CAVITY SPECIFICATION.
- 2 CONTINUOUS STRIP ON REELS WITH TERMINALS LOCATED ON ON .220 CENTERS.
- 3 SLOT ACCEPTS #23-#20 COPPER MAGNET WIRE.
- 4 AFTER INSERTION INTO PLASTIC HOLDER TAB PORTION MUST BE BENT OVER 45° TO 90° OR POTTED TO PREVENT PULL-OUT WHEN MATING RECEPTACLE IS DISCONNECTED.

63486-1

PART NO

UNLESS OTHERWISE SPECIFIED DIMENSIONS ARE IN INCHES TOLERANCES ON: 2 PL DEC ± - 3 PL DEC ± .010 ANGLES ± 1°	DR	M. S. FEHER	2/23/89
	CHK	JR RUTH	2/24/89
	APPD	NELSON E. NEFF	3/7/89
	APPD	C.G. ATHERTON	3/9/89
MATERIAL #4 HARD PRE-MILLED BRASS	PRODUCT SPEC		
FINISH	TIN	APPLICATION SPEC	114-2046 1
		WEIGHT	-



AMP INCORPORATED  
Harrisburg, Pa. 17105

NAME  
TAB, 110 FASTON,  
MAG-MATE™

SIZE	FSCM NO	DRAWING NO
B	00779	63486
SCALE	4:1	SHEET
		1 OF 1